

NTC 750 SERIES FAN COIL THERMOSTAT

GENERAL THERMOSTAT ON/OFF CONTROL



NTC 750 SERIES

NTC 750 series thermostat feature a on/off control for heating and cooling with fans speed switch. The controllers are designed for use in 2-pipe or 4 Pipe Fan Coil units, and a variety of heating and cooling applications controlled by water valves and damper actuator.

PRODUCT FEATURE

- Aesthetic design
- Constant and close temperature differential provided by bellow-type sensor
- System "OFF" position breaks all circuits
- All slide switches for ease of operation
- Easy to wire to numbered terminals

TECHNICAL SPECIFICATION

MODEL NUMBER	NTC 751	On-Off, 3-speed Fan, Single Output, Cooling Only or Heating Only, 2-pipe System
	NTC 752	Cool-Off-Heat, 3-speed Fan, Single or Dual Outputs, Manual Cooling/ Heating Changeover, 2-pipe System
NOMINAL OPERATING DIFFERENTIAL	Approximately 1 K	
RANGE	10-30° C Linear	
SENSING ELEMENT	Gas Bellow-type, Single-pole Double-throw Switch	
FAN OUTPUT	Continuous, Selectable at High, Medium or Low Speed	
BODY MATERIAL	Self-extinguishing, Molded ABS	
FINISH	Off White Color	
ELECTRICAL RATING	Thermostat - 10 A Resistive, 2.5A Inductive, 24 to 250 V 50/60 Hz Switches - 10 A Resistive, 2A Inductive, 24 to 250 V 50/60 Hz	
AMBIENT / STORAGE TEMPERATURE LIMIT	0 to 50° C / -30 to 50° C	
WIRE CONNECTION	Screw-down Connectors, wire size 1 mm ² or 18 AWG solid copper recommended	
CERTIFICATION	CE and ISO 9000 (EN...requirements)	
SHIPPING WEIGHT	0.24kg (0.53 lb)	
DIMENSIONS (mm)	L130 x W85 x D40 mm	

WIRING DIAGRAM

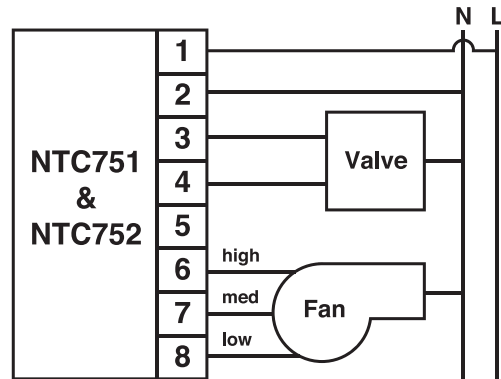

DIMENSION AND MOUNTING INSTRUCTION

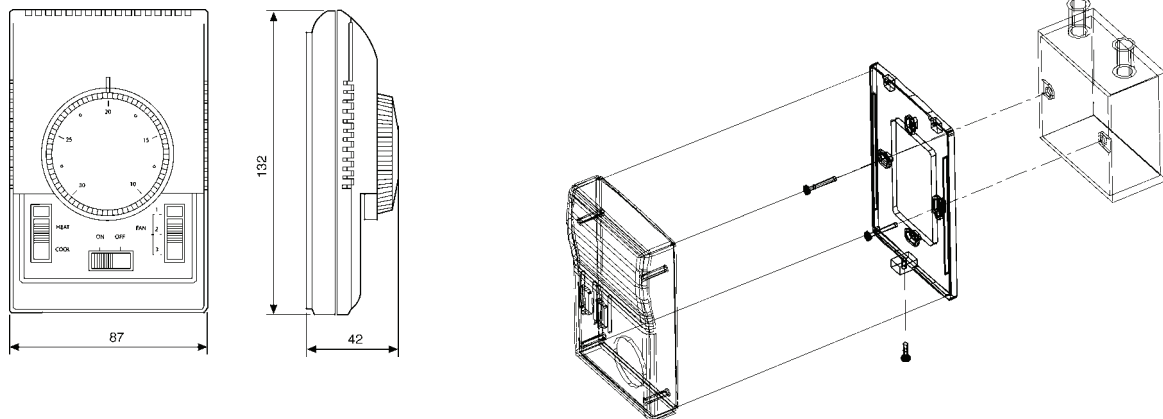

APPLICATION OVERVIEW

The NTC 750 Fan Coil Thermostat feature both 2 pipe and 4 pipe system for Fan Coil Units. The Thermostats can be ordered with NENUTEC Fan Coil Motorised Valve NVMZ / NVMB Series for a complete HVAC solution.