

NAY SERIES ELECTRIC BUTTERFLY VALVE ACTUATOR

VALVE & VALVE ACTUATOR



NAY SERIES

NAY series electric butterfly valve actuator is mainly use with Butterfly Valve in the HVAC system to regulate the flow of water and steam in response to the demand of a controller.

PRODUCT FEATURE

- Complete range from 80Nm to 3000Nm
- On/Off or Modulating
- 0-10VDC or 4-20mA Control Signal Selectable
- Control Modulating DC 0(2)...10 V
- High close-off pressure satisfies demanding requirements of high-rise buildings and high-pressure pumping systems
- Manual Handwheel

TECHNICAL SPECIFICATION

TORQUE	See TABLE 2: ACTUATOR CODE NUMBER SELECTION GUIDE
POWER SUPPLY	AC 220V ± 15%
FREQUENCY	50 / 60 Hz
PROTECTION CLASS	Class II
CONTROL SIGNAL	See TABLE 2: ACTUATOR CODE NUMBER SELECTION GUIDE
LIFE CYCLE	60,000 cycle
IP PROTECTION	IP 67
AMBIENT TEMPERATURE	-20°...50° as per IEC721-3-3
AMBIENT HUMIDITY	5...95% rH (non Condensing)
INVENTORY TEMPERATURE	+70°C as per IEC 721-3-2
WEIGHT	See TABLE 2: TECHNICAL DATA
CERTIFICATION	CE and ISO 9000 (EN...requirements)

TABLE 1: ACTUATOR CODE NUMBER DESIGNATION

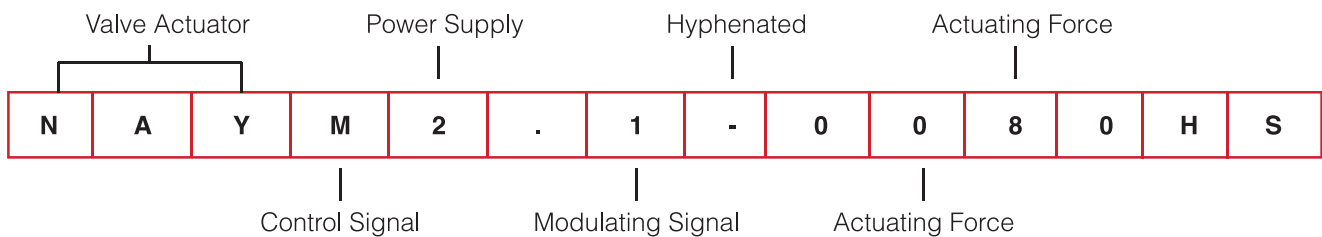

TABLE 2: ACTUATOR CODE NUMBER SELECTION GUIDE

VALVE ACTUATOR NAV		NAY = Butterfly Valve Actuator		
CONTROL SIGNAL	A = On / Off			
	M = Modulating Control			
POWER SUPPLY	2 = AC 220V ac			
MODULATING SIGNAL (APPLICABLE FOR MODULATING SIGNAL)	1 = 0 - 10 Vdc or 0(4)-20 mA			
TORQUE	0080 = 80Nm	0500 = 500Nm	1500 = 1500Nm	
	0150 = 150Nm	0800 = 800Nm	2000 = 2000Nm	
	0350 = 350Nm	1100 = 1100Nm	3000 = 3000Nm	

TABLE 3: TECHNICAL DATA

MODEL		POWER (W)	MAX OUTPUT TO TORQUE (Nm) AC220V/50HZ 1 PHRASE	OPEN/CLOSE TIME (SEC)	ISO 5211 STD	WEIGHT (KG)	REMARK
ON/OFF NAY 2	MODULATING NAYM 2.1						
	0080HS	15	80	14	F07	7	with handwheel
	0150HS	40	150	21	F07/10	15	
	0350HS	40	350	26	F10/F12	20	
	0500HS	90	500	31	F12/F14	20	
	0800HS	180	800	31	F12/F14	25	
	1100HS	180	1100	39	F12/F14	25	
	1500HS	90	1500	93	F16	65	
	2000HS	180	2000	117	F16	75	
	3000HS	180	3000	117	F16	75	

TABLE 4: MAXIMUM CLOSE-OFF PRESSURE (KPA)

MAXIMUM SHUTOFF PRESSURE (KPA) WITH NVBF SERIES VALVE												
MODEL	TORQUE (Nm)	DN100	DN125	DN150	DN200	DN250	DN300	DN350	DN400	DN450	DN500	DN600
0080HS	80	700	500									
0150HS	150		700	700								
0350HS	350				700	500						
0500HS	500					700	500					
0800HS	800							700				
1100HS	1100								700	500		
1500HS	1500									700	500	
2000HS	2000										700	
3000HS	3000											700

NAY SERIES ELECTRIC BUTTERFLY VALVE ACTUATOR

VALVE & VALVE ACTUATOR

DIMENSIONS (mm)

0080HS - 1100HS

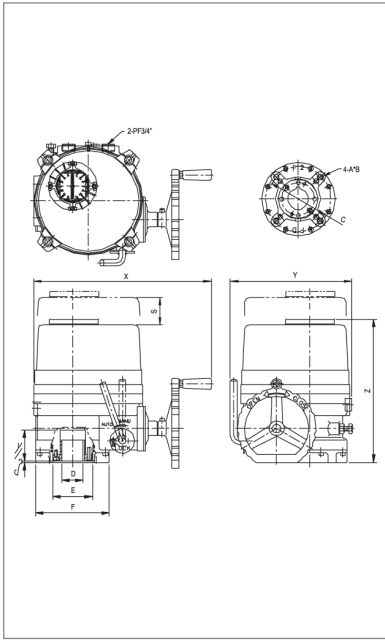

TYPE	0080HS	0150HS	0350HS	0500HS	0800HS	1100HS
FLANGE	F07	F07	F10	F10	F12	F12
ISO5211		F10	F12	F12	F14	F14
C	Ø 70	Ø 70	Ø 102	Ø 102	Ø 125	Ø 125
		Ø 102	Ø 125	Ø 125	Ø 140	Ø 140
A	M8	M8/M10	M10/M12	M10/M12	M12/M16	M12/M16
B	14	14/17	17/21	12/21	20/25	20/25
D (KEY)	Ø 22	Ø 25	Ø 40	Ø 40	Ø 48	Ø 48
D (SQU.)	□ 20	□ 23	□ 34	□ 34	□ 40	□ 40
E	Ø 50	Ø 58.5	Ø 80	Ø 80	Ø 95	Ø 95
F	Ø 88	Ø 125	Ø 148	Ø 148	Ø 178	Ø 178
G	3	3	3	3	3	3
H	37	57	62	62	67	67
S	100	115	145	145	170	170
X	258	338	357	357	380	380
Y	172	229	244	244	287	287
Z	220	259	288	288	313	313

1500HS - 3000HS (With Gear Box)

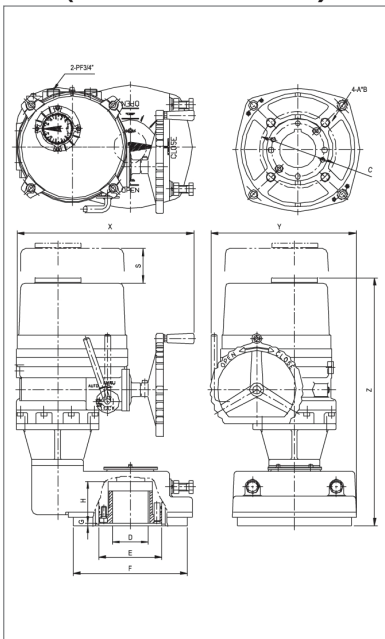

TYPE	1500HS	2000HS	3000HS
FLANGE	F16	F16	F16
ISO5211			
C	Ø 165	Ø 165	Ø 165
A	M20	M20	M20
B	32	32	32
D (KEY)	Ø 75	Ø 75	Ø 75
D (SQU.)	□ 64	□ 64	□ 64
E	Ø 135	Ø 135	Ø 135
F	Ø 245	Ø 245	Ø 245
G	5	5	5
H	90	90	90
S	145	170	170
X	368	380	380
Y	293	312	312
Z	506	531	531

WIRING DIAGRAM

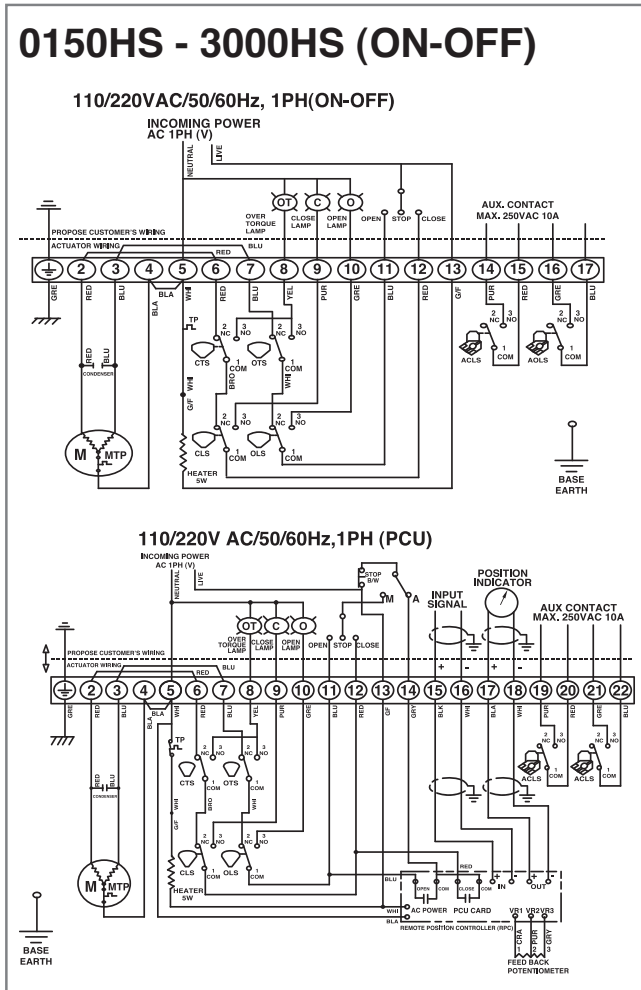
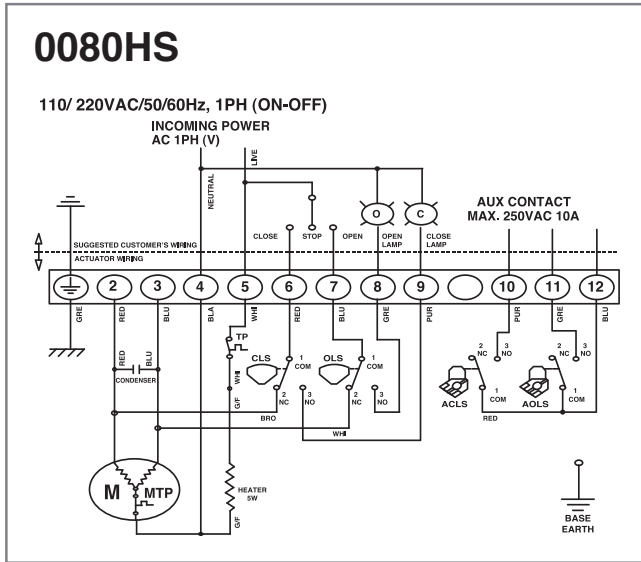

PCU WIRING DIAGRAM

